

012 Air Boxes

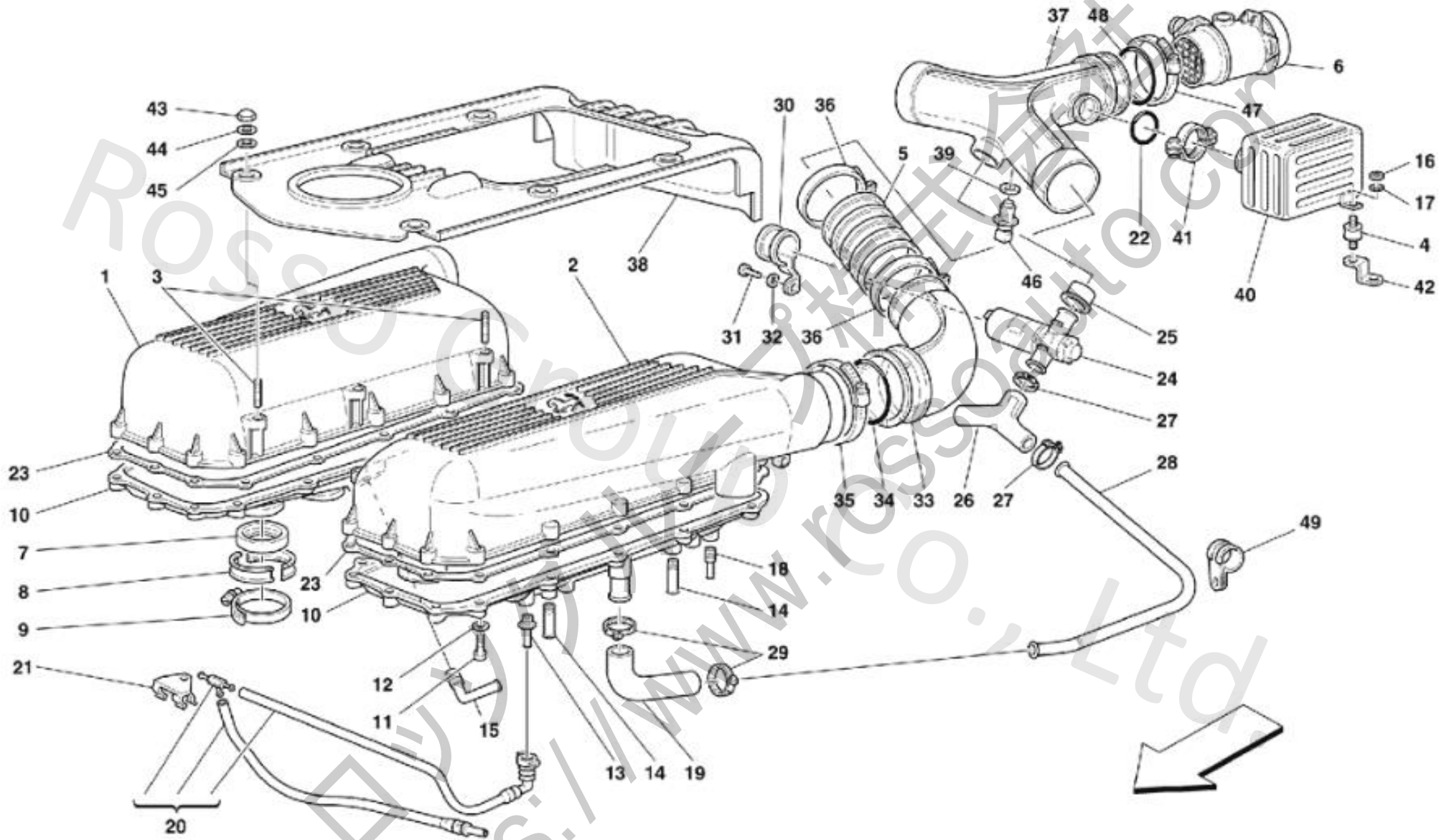

012 Air Boxes

No.	Part No.	Name	Qty
0	170019	COMPLETE L.H. AIR FEEDING PLENUM CHAMBER AND COVER	1
0	167479	COMPLETE L.H. AIR FEEDING PLENUM CHAMBER AND COVER	1
0	167478	COMPLETE R.H. AIR FEEDING PLENUM CHAMBER AND COVER	1
0	170018	COMPLETE R.H. AIR FEEDING PLENUM CHAMBER AND COVER	1
1	168709	R.H. AIR FEEDING PLENUM CHAMBER	1
1	167478	R.H. AIR FEEDING PLENUM CHAMBER	1
2	167479	L.H. AIR FEEDING PLENUM CHAMBER	1
2	170019	L.H. AIR FEEDING PLENUM CHAMBER	1
3	11500724	STUD	6
4	113021	PAD	1
5	160701	SLEEVE	2
6	162397	AIR FLOW METER	1
7	145643	GASKET	8
8	169452	HALF RING	16
9	145645	CLAMP	8
10	167356	LOWER COVER	2
11	186196	SCREW	32
12	12601274	WASHER	32
13	160846	THREADED UNION	2
14	129808	THREADED UNION	2
15	153926	THREADED UNION	2
16	169180	NUT	1
17	12644424	WASHER	1
18	170444	THREADED UNION	2
19	164279	PIPE FROM REGULATOR TO PLENUM CHAMBER	2
20	166494	COMPLETE ANTI-EVAPORATION PIPING	1
21	128292	CLIP	1
22	153628	O.R. GASKET	1
23	153381	GASKET	2
24	162406	REGULATOR FOR IDLE	1
25	164337	SLEEVE	1
26	164278	SLEEVE	1
27	13000490	SCREW COLLAR	3
28	164300	L.H. AIR DELIVERY TUBE	1
28	164299	R.H. AIR DELIVERY TUBE	1
29	13000490	SCREW COLLAR	4
30	164284	BRACKET WITH SHEATH	1
31	16043224	SCREW	1
32	12601374	WASHER	1
33	168685	L.H. AIR DELIVERY SLEEVE	1
33	168684	R.H. AIR DELIVERY SLEEVE	1
34	149666	O.R. GASKET	1
35	171001	CLAMP	2

012 Air Boxes

36	13001090	SCREW COLLAR	4
37	164225	AIR DELIVERY Y TUBE	1
38	159517	SHIELD	1
39	10296160	GASKET	1
40	168783	DUCT	1
41	168902	CLAMP	1
42	168911	BRACKET	1
43	100044	NUT	2
44	14496424	WASHER	2
45	113113	WASHER	2
46	162419	AIR TEMPERATURE SENSOR	1
47	171000	CLAMP	1
48	126596	O.R. GASKET	1
49	10441790	BRACKET WITH SHEATH	1
49	179203	FLEXIBLE CLIP	1

ロッセオ自動車株式会社
<https://www.rossoauto.com>